

**CRESCENT HARDWOOD SUPPLY**  
New Orleans~Baton Rouge~Mobile  
Jackson~Houston  
Since 1918

## Premier Hardwood Adhesive

**LOCK  
and GO**

**Adhesive only  
&  
2-In-1  
Moisture Control  
Option!**

**3349**

Lock And Go 3349 offers a high initial tack and proven bond strength that lasts! With an easy to spread and easy to clean formula, 3349 contributes to an eco-friendly installation and dramatically increases installer productivity.

### For Use With:

- Multi-Ply Engineered Plank
- Exotic Multi-Ply Engineered Plank
- Solid Wood Flooring
- Plain-Back Parquet
- **Not For Use With Strand Bamboo for Moisture Warranty**

### Features:

- Excellent Suction Bond
- Superior Green Grab
- Wet-Set Tack
- Moisture Control up to 12 lbs.
- Eco-Friendly Adhesive
- Easy to Clean When Wet
- Low Odor & Nonflammable
- Dual Purpose Product
- Helps Contribute to LEED
- Tenacious, Permanent Bond

**Crescent Hardwood Supply**  
1101 Sams Avenue • Harahan, LA 70123  
800-229-7325

## INSTRUCTIONS (ADHESIVE ONLY & 2-IN-1 MOISTURE CONTROL)

Read and understand all information below before installation. If there are any questions, please call **Crescent Hardwood Supply at 800-229-7325**. It is the responsibility of the installer to determine proper drying time of the adhesive, how much set up time is needed for the adhesive, applicable trowel size for the product being installed and acceptability of subfloor conditions. The time it takes for the adhesive to cure is related to temperature, humidity, porosity of the subfloor, ventilation and air movement. **Lock and Go 3349 Premier Hardwood Adhesive is moisture resistant, however, to prevent damage to the flooring from subfloor moisture, carefully follow the wood manufacturer's instructions. Flooring must be rolled with a 100 lb. roller within 2 hours of installation.**

### APPROVED SUBFLOORS (ADHESIVE ONLY)

- Plywood
- Vinyl tile flooring coated with vinyl primer
- Underlayment grade O.S.B.
- A.P.A. PS-92 rated particleboard
- Concrete; above, on or below grade
- Light weight concretes (coated with latex primer)
- Terrazzo and ceramic tile
- Non-cushioned fully adhered sheet vinyl coated with vinyl primer

### APPROVED SUBFLOORS (2-IN-1 MOISTURE CONTROL)

- Concrete; above, or on-grade
- Light weight concrete (coated with latex primer) above-grade

## GENERAL SUBFLOOR PREPARATION (ADHESIVE ONLY & 2-IN-1 MOISTURE CONTROL)

- **Clean** - It is required that all unsealed concrete, well bonded sheet vinyl, terrazzo and ceramic tile sub floors be scoured with #3-1/2 open coat (20 grit) sandpaper to remove dirt or any surface contamination such as paint, grease, oil, sealers, waxes and curing compounds. **Lock and Go 3349 Premier Hardwood Adhesive** should not be used over these substances. Sweep or vacuum the subfloor before installation.
- **Preparation** - All floors should be flat to within 3/16" in 10 ft. or 1/8" in 6 ft. Not properly flattening the substrate to industry standards may result in voids in the moisture control membrane when this product is used as a 2-In-1 system. This can allow moisture to adversely affect the wood flooring and is not covered by the substrate moisture warranty.
- **Smooth and Flat** - Remove any high spots with a terrazzo grinder or sander and fill any low spots with a good quality cementitious-based patch mix designed for high moisture conditions.

## CONCRETE SUBFLOORS (ADHESIVE ONLY & 2-IN-1 MOISTURE CONTROL)

Concrete should be at least 60 days old. Inspect the concrete before installing flooring over it. First inspect for any wetness at the base of the drywall or for visible signs of moisture on the concrete. Second, test for moisture. Use a Calcium Chloride Test for a reliable concrete test. If the results are 3 lbs. MVER or less, per the ASTM 1869 Calcium Chloride Method Test, use **Lock and Go 3349 Premier Hardwood Adhesive** with the required adhesive bond only trowel. If the results are between 3 lbs. and 12 lbs. MVER, use **Lock and Go 3349 Premier Hardwood Adhesive** with the required moisture control trowel. For applications over 12 lbs MVER, use LNG MCA, which has no upper limit MVER. Follow the light weight concrete manufacturer's recommendation for the application of a surface hardener/sealer. Radiant heated subfloors should be turned off 24 hours prior to and during installation to prevent premature curing of the adhesive.



## WOOD INSTALLATIONS (ADHESIVE ONLY & 2-IN-1 MOISTURE CONTROL)

**Lock and Go 3349 Premier Hardwood Adhesive flows from the pail very easily. For best results, tip the pail carefully to dispense adhesive.** Provide adequate ventilation and air movement. Ideally, installation should not begin until all wet work (painting, dry wall materials, etc.) is complete and the heating/air conditioning system is in operation. Jobsite temperature should be between 55 and 90 degrees Fahrenheit. Trowel only the amount of adhesive that can be covered in 30 minutes. Install wood flooring into wet adhesive only. Secure the first row with edge blocking or top nail with finishing or sprig nails. Tighten side and end joints and reduce scooting by securing the flooring together with 3M Blue 2090 Delicate tape. Occasionally check for transfer to back of wood flooring. If adhesive transfer is less than 90% to the back of the plank scrape up the adhesive and apply fresh **Lock and Go 3349 Premiere Hardwood Adhesive**. **Adhesives transfer when using this product as a 2-in-1 system must be 100%**. Apply weight to any bowed flooring and all floor mounted trim moldings. Remove all defective or unsightly boards immediately. The adhesive is very tenacious and flooring is difficult to remove after the adhesive has cured. Roll the floor with a 100 lb. roller every two hours during and immediately after installation.



## LIMITATIONS (ADHESIVE ONLY & 2-IN-1 MOISTURE CONTROL)

When used as an adhesive only, this adhesive will not prevent moisture-related damage to wood flooring installations. **Lock and Go 3349 Premier Hardwood Adhesive** is affected by the environment, i.e. humidity and temperature. High humidity will cause the adhesive to cure faster and low humidity will slow the curing process. Do not use on wet, contaminated or friable substrates. After 8 hours, light traffic is allowed. Do not use as a leveling material. Completely remove all adhesive residue and other surface contaminants by diamond grinding, shot blasting, or scarifying.

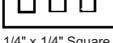
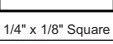
### TROWELS AND COVERAGE For Adhesive Bond Only

Floor Type	Trowel	Coverage
multi-ply engineered plank 3/8" up to 1/2"	 3/16" x 3/16" x 5/32" V Notch	50 sq. feet/gal.
1/4" engineered plank	 1/8" x 1/8" x 1/8" Square Notch	80 sq. feet/gal.
4' x 4' plywood	 1/4" x 1/4" x 1/4" Square Notch	30 sq. feet/gal.
Greater than 1/2" engineered plank, 3/4" parquet and 1/2" solid glue down pine	 1/4" x 1/4" x 1/8" Square Notch	35 sq. feet/gal.
Use Lock and Go 3349 Premier Hardwood Adhesive with a properly notched trowel. All square footage rates are estimated. Rates will vary based on substrate condition and the angle the trowel is held to the subfloor. Crescent Hardwood Warranties do not cover problems caused by improper use of installation products. Follow flooring manufacturers written installation instructions.		

### TROWELS AND COVERAGE Required Trowel to Achieve Moisture Warranty

Floor Type	Trowel	Coverage
multi-ply engineered plank wood flooring up to 5/8" thick	 1/4" x 3/16" V Notch	30 sq. feet/gal. * Depending on slab texture
multi-ply engineered plank wood flooring greater than 5/8" thick and 1/2" solid glue down pine	 1/2" x 15/32" V Notch	20 sq. feet/gal. * Depending on slab texture
Use Lock and Go 3349 Premier Hardwood Adhesive with a properly notched trowel. Each trowel can spread a maximum of 800 sq.ft. of Lock and Go 3349 adhesive. Once 800 sq.ft. is reached, a new trowel is required. Note: Using a trowel other than the trowel recommended, voids the warranty. All square footage rates are estimated. Rates will vary based on substrate condition and the angle the trowel is held to the subfloor. Crescent Hardwood Warranties do not cover problems caused by improper installation. Follow flooring manufacturers written installation instructions. Use a Calcium Chloride Test for reliable concrete testing. When the required trowel is used, Lock and Go 3349 adhesive is warranted for up to 12 lbs/1,000 ft <sup>2</sup> /24 hrs, per the ASTM 1869 Calcium Chloride Method Test.		

## SHELF LIFE (ADHESIVE ONLY & 2-IN-1 MOISTURE CONTROL)

12 months when stored at 75° F and 50% relative humidity.

## CLEAN UP (ADHESIVE ONLY & 2-IN-1 MOISTURE CONTROL)

- **Remove excess urethane adhesive as soon as possible before it dries on the flooring surface. Clean up as you go. Cured urethane adhesive is very difficult to remove.**
- **Never attempt to remove Lock and Go 3349 Premier Hardwood Adhesive from tools or flooring with water as this will cause the adhesive to cure more rapidly.**
- Remove residue before it dries with Urethane Adhesive Remover.
- Clean **Lock and Go 3349 Premier Hardwood Adhesive** from floor and tools while still wet with Urethane Adhesive Remover.

## REUSE OF PARTIAL CONTAINERS (ADHESIVE ONLY & 2-IN-1 MOISTURE CONTROL)

Cover adhesive in pail with plastic trash bag or two layers of plastic film. Put lid on tightly. Turn over pail. This will seal contents from outside air. To open container, take off lid, cut plastic and remove thin layer of cured adhesive on surface.